

Unlock superior rig
productivity with Harlsan's
advanced drilling solutions



HARLSAN

Revolutionizing RC Drilling: Harlsan's Impact on Rig Efficiency

A leader in the RC drilling industry approached us after experiencing significant benefits from their initial Harlsan equipment. They were facing considerable maintenance challenges with their existing top swivels and overall rig setup provided by a competitor. We introduced our more efficient bottom swivel design, simplifying operation and dramatically reducing maintenance costs and downtime.

Another ongoing challenge related to blockages and blow down failures that were impeding productivity. The introduction of our Flotec hydraulic blow down system addressed these issues efficiently, ensuring a return to smooth and continuous operations.

In order to objectively assess the impact of Harlsan's solutions, the customer conducted a rigorous performance comparison with the competitor's setup, using side-by-side rigs on the same site. The results were unequivocal: Harlsan's setup vastly outperformed the alternatives, marking a substantial advancement in drilling efficiency.

Encouraged by these findings, the entire team—from drillers to supervisors—embraced Harlsan's quality equipment, exceptional support (including engineering assistance and detailed technical drawings) and innovative solutions. Drilling efficiency improved so much, they have prioritised transitioning all their rigs to complete Harlsan setups.

Dramatic Performance Gains



Boosted productivity: With a full Harlsan setup, drilling metrics improved dramatically, achieving 31% more annual drilling hours, and maintaining 93.85% equipment availability.



Reduced revenue loss: A Harlsan setup drastically decreased lost contract revenue by 15 times, compared to previous rig configurations.



Less downtime: Implementing a full Harlsan setup led to a 15-fold reduction in lost shifts, outperforming competitors at the same site.



Lower maintenance needs: The Harlsan setup makes maintenance quicker, easier and safer. This slashed maintenance hours by more than half, with head maintenance hours reduced by an impressive 94%.

AT A GLANCE

Challenges:

- **Maintenance Issues**
Frequent maintenance challenges with top swivels and rig setups.
- **Operational Complexity**
Convolutd top swivel design complicating operations.
- **Blockages and Failures**
Persistent blockages and blow down failures reducing productivity.
- **Performance Validation**
Need for a detailed performance comparison to validate new setups.

Successes:

- **Efficiency Improvement**
Introduced a more efficient bottom swivel design, reducing maintenance costs and downtime.
- **Operational Solutions**
Implemented Flotec® hydraulic blow down system to resolve blockages and ensure continuous operations.
- **Performance Validation**
Rigorous comparison showed Harlsan setups outperformed alternatives, greatly enhancing drilling efficiency.
- **Teamwide Commitment**
Complete adoption of Harlsan's comprehensive support and quality equipment across all rigs, by the entire team.

Your rig, optimised.

Harlsan's world class equipment and innovative engineering combine to optimise your rig's profitability and make ongoing maintenance quicker, safer and easier. Our setup is game-changing and we will work closely with you to ensure a seamless integration.

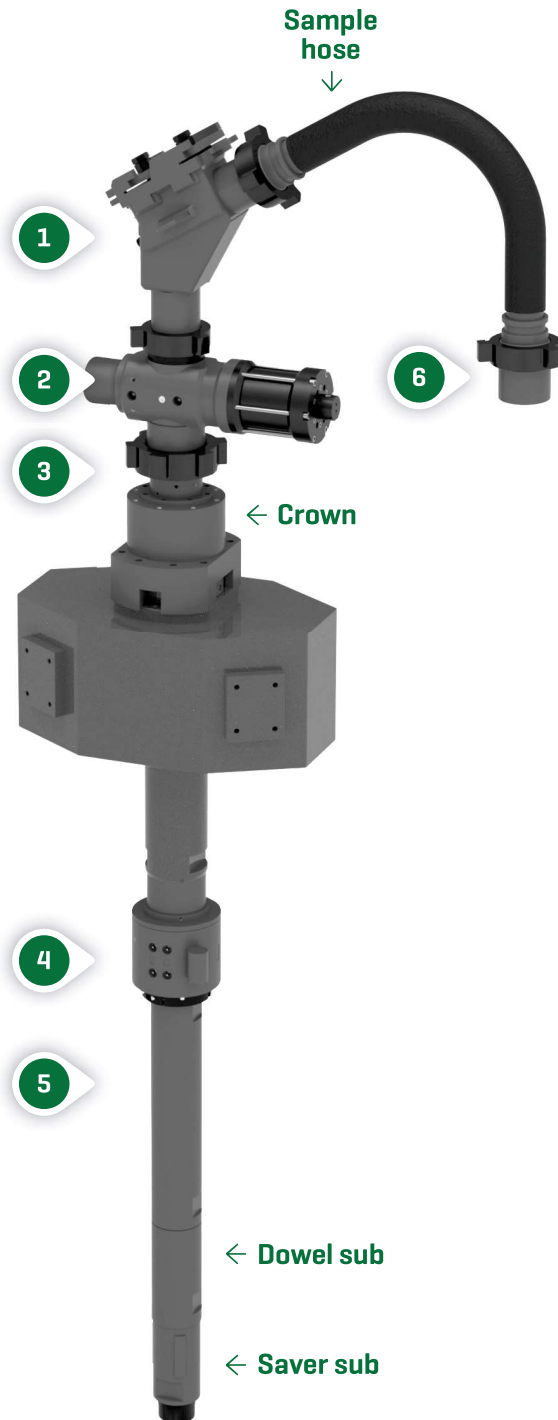

1
Wearlok®
wear bend



2
Flotec®
hydraulic
blow down



3
Top swivel/
seal plate



4
Bottom
swivel



5
Subs



6
Hose tail,
Diffuser,
Knock-on nuts

